

# QUINTA DO GERARDO E CATARINO

OPERAÇÃO DE LOTEAMENTO - COGEDIR SA  
SANTO ANTÓNIO DA CHARNECA, BARREIRO





**PLANTA DE LOCALIZAÇÃO**  
QUINTA DO GERARDO E CATARINO  
SANTO ANTÓNIO DA CHARNECA, BARREIRO







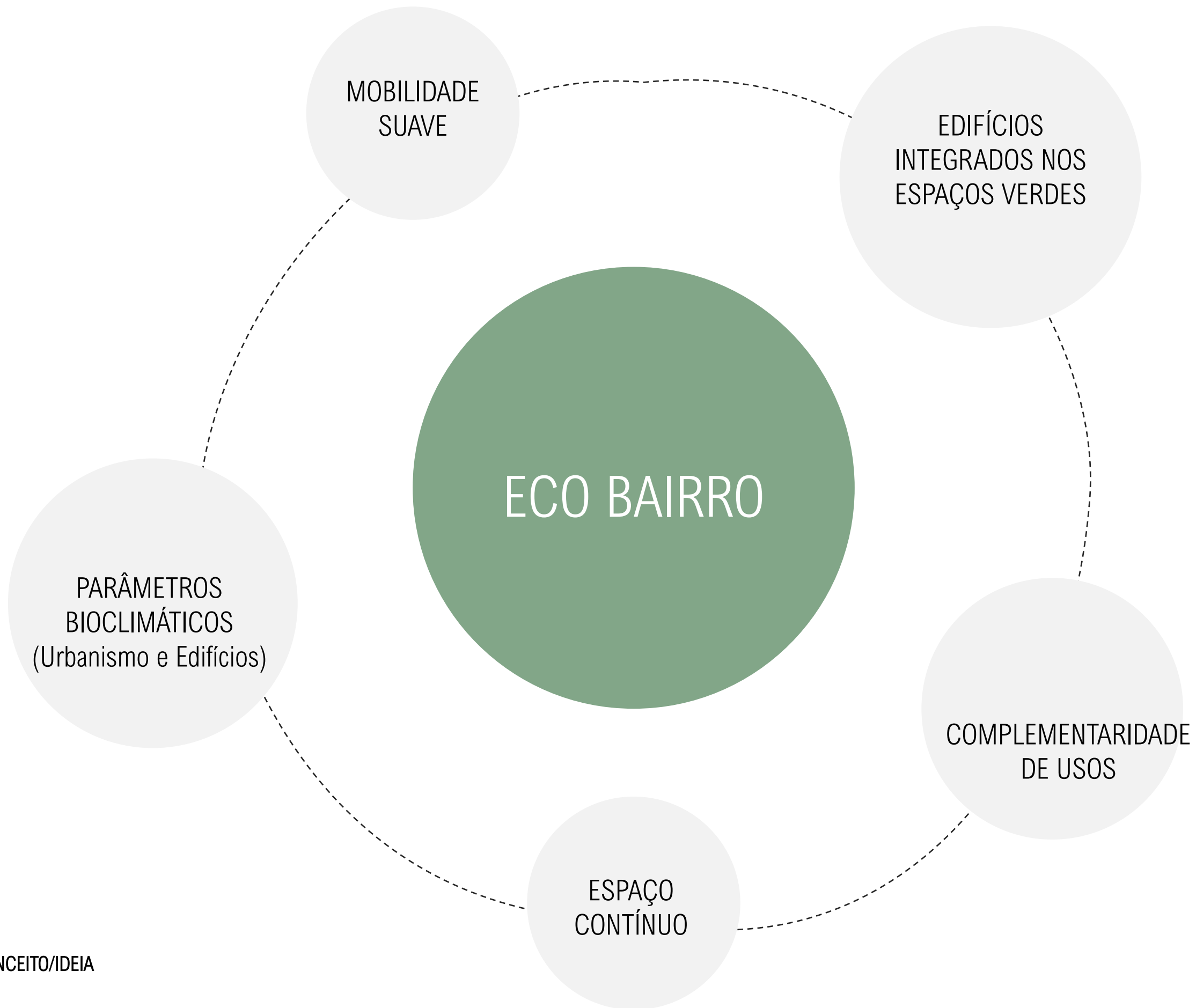

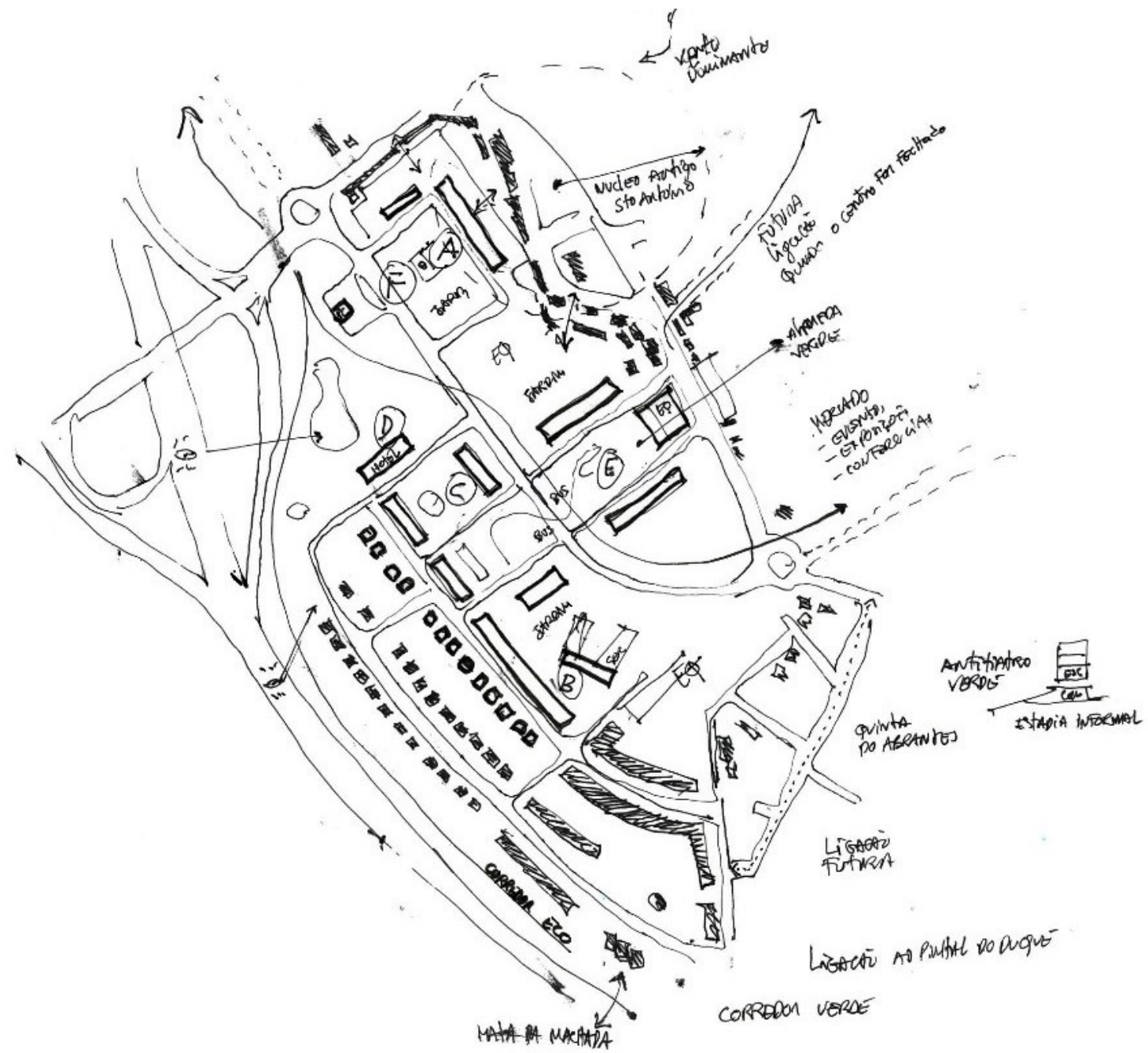



PLANTA DE CONJUNTO





PLANTA DE USOS

 HABITAÇÃO

 SERVIÇOS

 EQUIPAMENTOS E ESPAÇOS VERDES COLECTIVOS

 ÁREAS COMERCIAIS





USO - HABITAÇÃO

 HABITAÇÃO

Área Bruta de Construção Proposta – **38 837,07 m<sup>2</sup> (70%)**  
Nº Fogos Máximo – **234 Habitações**  
População Residente Estimada - **702 Pessoas**





USO - SERVIÇOS

 SERVIÇOS

Área Bruta de Construção Proposta – **10 944,95 m2 (19%)**





## USO – EQUIPAMENTOS E ESPAÇOS VERDES COLECTIVOS

 EQUIPAMENTOS E ESPAÇOS VERDES COLECTIVOS

Área Bruta de Construção Proposta – **4 694,09 m<sup>2</sup> (7%)**





USO – ÁREAS COMERCIAIS

ÁREAS COMERCIAIS

Área Bruta de Construção Proposta – 1 990,67 m<sup>2</sup> (4%)



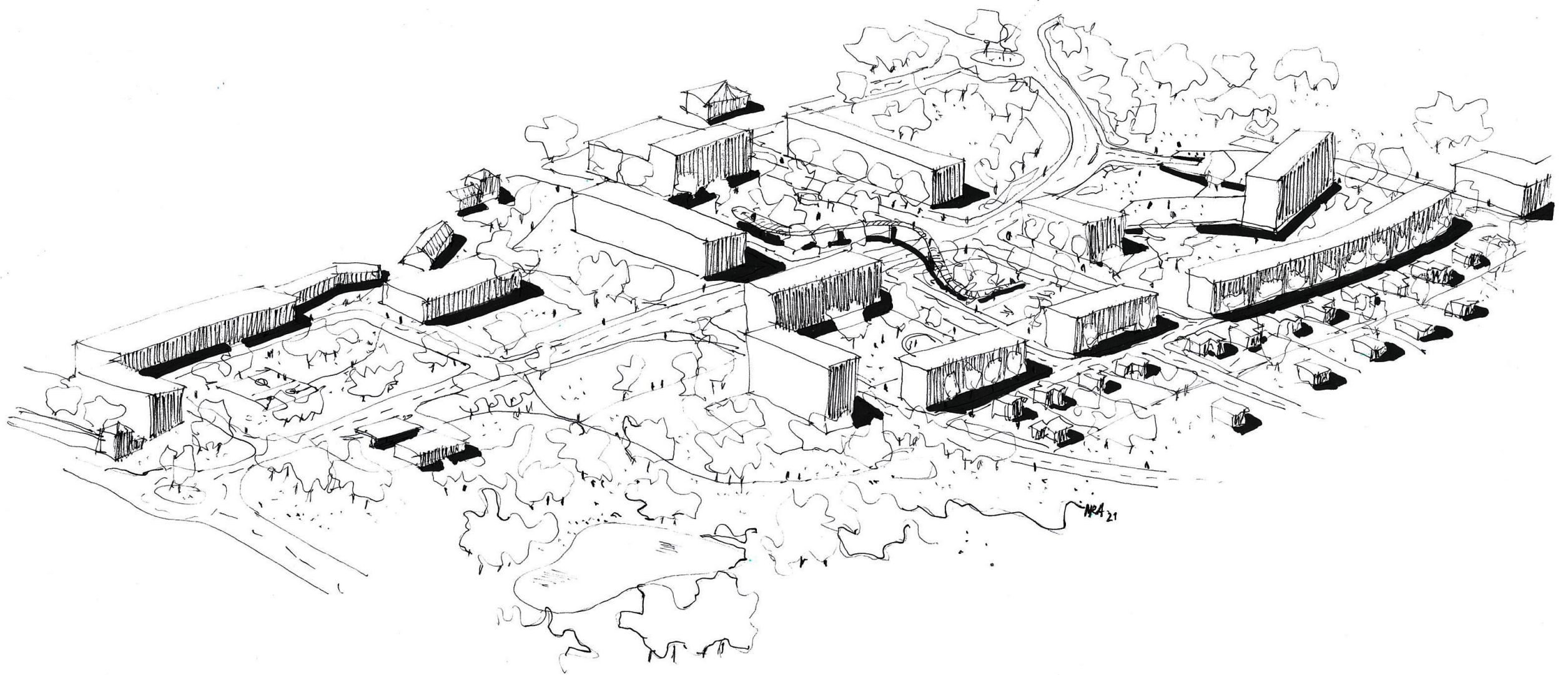

Descrição	Área dos Lotes (m2)	ABC Comércio (m2)	ABC Habitação (m2)	ABC Serviços (m2)	ABC Equipamentos (m2)	Nº Fogos
UOPG 129	8694,65	914,86	8240,00	1920,00	4694,09	51
UOPG 130	28318,74	1075,81	30597,07	9024,95	0,00	183
<b>Total</b>	<b>37013,39</b>	<b>1990,67</b>	<b>38837,07</b>	<b>10944,95</b>	<b>4694,09</b>	<b>234</b>

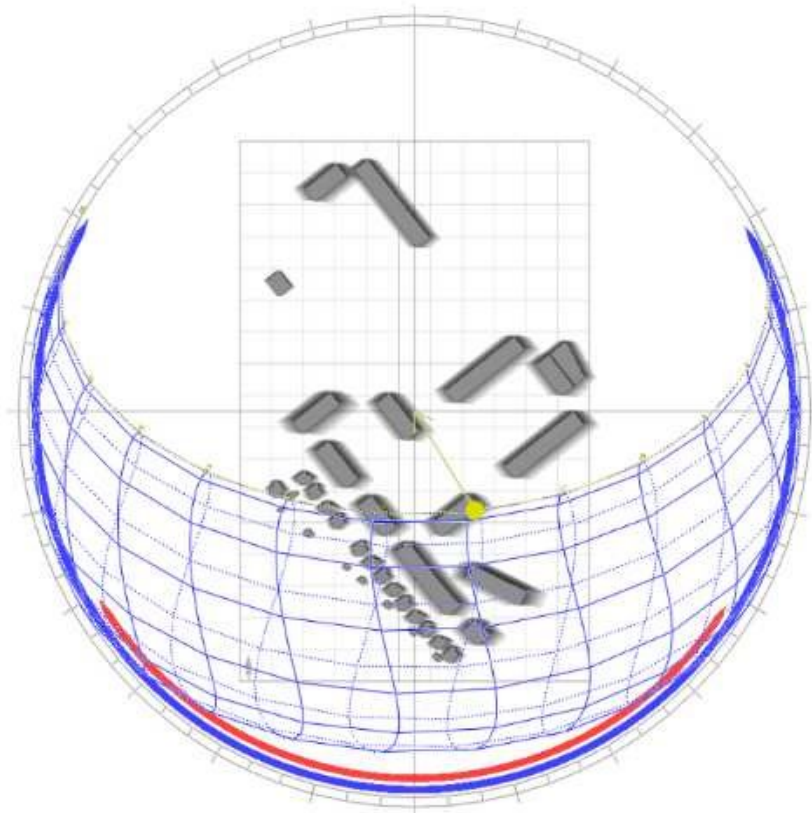

Solstício de Verão

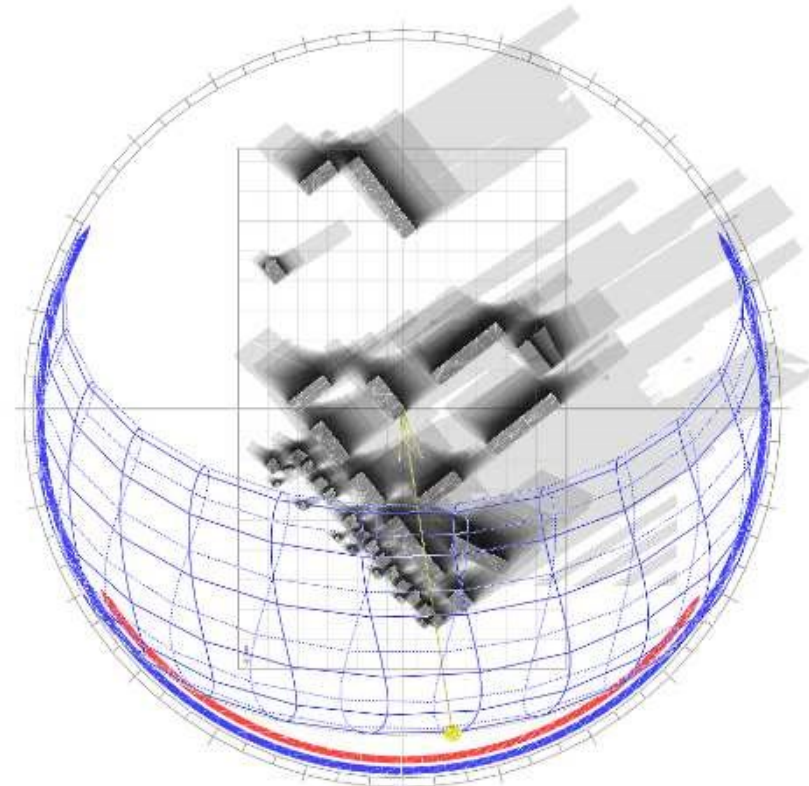

Solstício de Inverno

